

safe · timeless · beautiful



markilux 1300 stretch

The perfect solution for narrow terraces, niches and balconies.



markilux 1300 stretch

The perfect solution for narrow patios, niches and balconies.

design features

- the markilux 1300: The classic shape of an open patio awning
- for long-lasting attractiveness the awning has been powder coated.
- awning covers made from acrylic yarns or sunsilk SNC with self-cleaning effect.
- The panel joints of the awning cover are ultrasonically bonded - for an improved appearance without bothersome stitching.
- In the case of manual operation with a markilux stainless steel winding handle - quality to get to grips with

technical highlights

- The reliable awning with a large number of configuration options.
- Attractive front profile made of extruded aluminium with integrated gutter and water drainage spouts.
- Thanks to this innovative technical solution - tiered arms - large extensions can still be achieved in narrow awnings.
- The 85 mm roller tube ensures the highest rigidity and the best possible cover winding characteristics even at the largest widths.

optional accessories

- In the case of manual operation ease of use is ensured with the spring-assisted gearbox.
- Hard-wired motor drive (optionally with automatic controls) for simple, relaxed operation.
- Radio-controlled motor with handheld transmitter for ease of operation - and ergonomically crafted for ease of use.
- The shadeplus creates an additional room on the patio. Protection from sun, wind and inquisitive glances in one.
- An easily connected sun and wind sensor provides intelligent control and essential protection.

- Folding arms with perfected force transference via a rounded, chain-link coupling
- drop-forged joint components made of aluminium
- The pivot bolts sit in Teflon-coated bronze bushes for high stability and longevity
- The greater upper to lower arm length ratio gives high lateral awning stability
- Fixture brackets are made of extruded aluminium
- A coverboard made of extruded aluminium and fitted with a rubber sealing strip is available
- The awning is available in non-standard RAL colours

Folding-arm awning markilux 1300 stretch



folding arm with round, steel-link chain

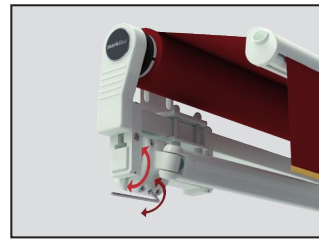

simple pitch adjustment



side view with awning closed, face fixture

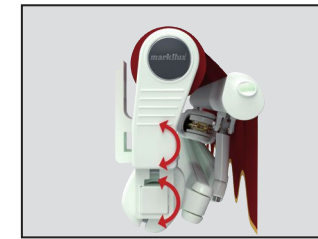

Pitch adjustment possible up to 25°

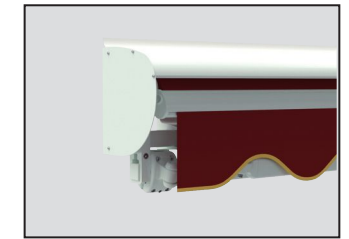

with shadeplus (optional)



shadeplus integrated in the front profile (optional)

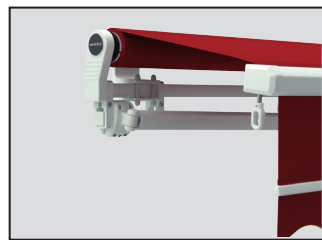

during extension with shadeplus (optional)

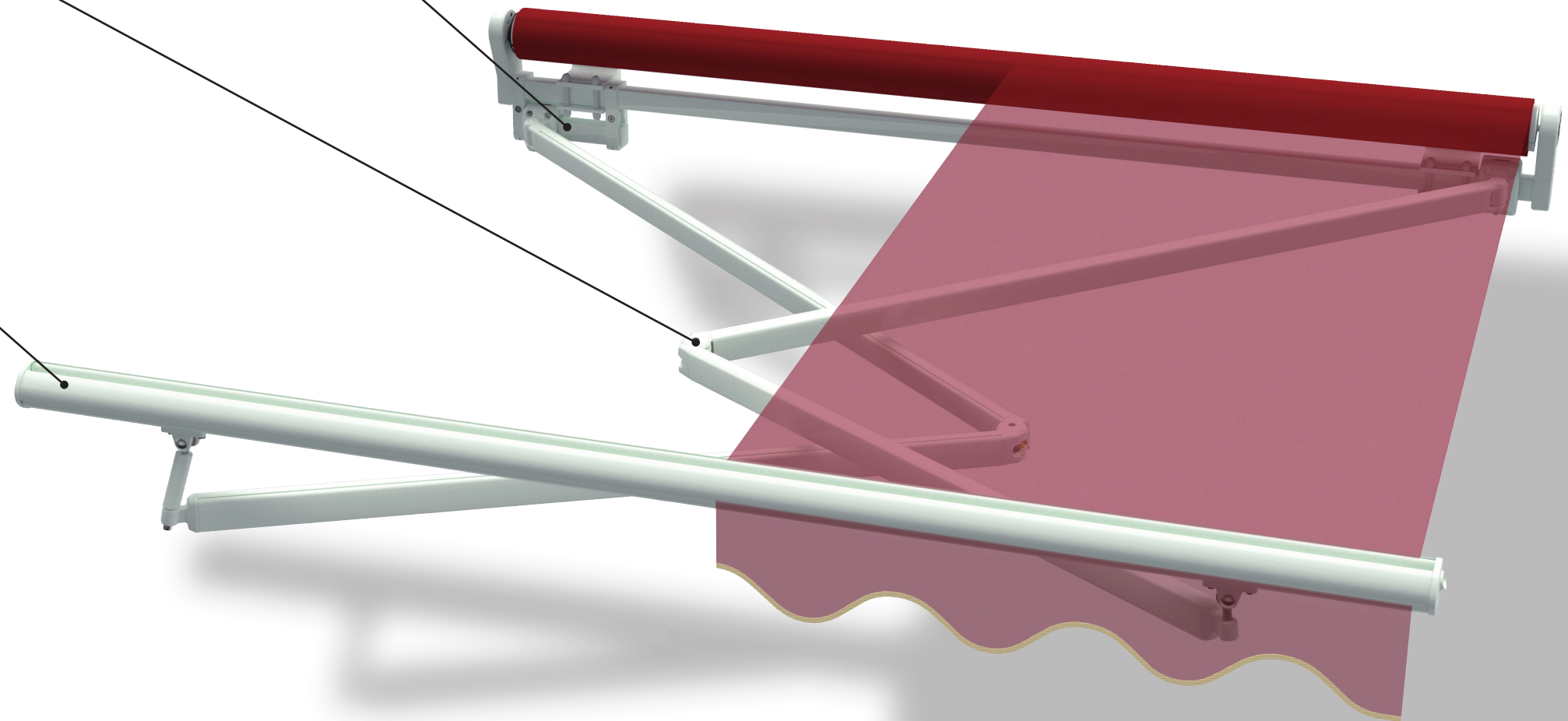

Standard RAL colours:



standard:

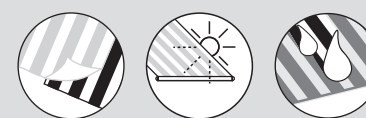

optional accessories:



safe · timeless · beautiful



markilux 1300 stretch

The perfect solution for narrow patios, niches and balconies.

markilux

dimensions and configuration options

extension	Overall blind width							minimum width motor ¹⁰⁾		minimum width manual operation ¹⁰⁾	
	150 114-150	175 151-175	200 176-200	225 201-225	250 226-250	300 251-300	350 301-350	Standard	Bespoke arms	Standard	Bespoke arms
150	28)		13)					127	114	130	117
200	28)			13)	13)			152	139	155	142
250		28)				13)		177	164	180	167
300			28)				13)	202	189	205	192
350				28)				227	214	230	217

10) the dimensions are only valid for fixture without spreader plates (2 folding arms).

13) intermediate widths on request

28) Please note the minimum widths!

dimensions in cm

 = available, 2 folding arms

operation type	
manual operation with st. steel winding handle	●
Servo-assisted operation	○
radio-controlled motor	○
motor	○
Shadeplus	
manual operation	○
radio-controlled motor	–
motor	○
Lighting	
Halogen Spotlights	–
Fluorescent lighting	–
covers	
acrylic 34 (fabric series 341xx-347xx)	●
sunsilk SNC (fabric series 324xx/329xx)	●
signature (fabric series 369xx)	●
transilk FR (fabric series 319xx)	–
transolair (fabric series 339xx)	–
widely woven acrylic (fabric series 349xx)	○ ¹⁾
perla FR (fabric series 374xx/379xx)	○
Soltis 92	○ ²⁾
PVC fabric	○ ²⁾
miscellaneous	
Coverboard	○
Sytem coverboard	–
wall sealing profile	–
Pitch adjustment gear	–
Insertable side blind	○
sun and wind sensor	○
Valance	● ²⁾
Infrared heater	○
Vibrabox / Sunis sun sensor	○
Coupled units (please refer to fixture)	
coupled unit 2 fields	–
coupled unit 3 fields	–
junction roller	–
one-piece cover (on request)	–

● = fitted as standard

○ = optional accessory

– = not available

○²⁾ = PVC/Soltis 92 covers up to a max. extension of 250 cm.

○¹⁾ = widely woven fabric up to a max. extension of 300 cm.

●²⁾ = valance shape 2 (please refer to the section "Fabric Collection")

Definition of extension: The nominal extension is measured with the awning extended at a pitch of approx. 15° from the wall over the cover to the leading edge of the front profile. The tolerance in the extension is -40 mm / +40 mm

In the case of manual operation, assume approx. 16 winding handle revolutions per metre of awning extension.

Extension when using a motor takes approximately 12 seconds per metre.





Definition of shadeplus drop: The shadeplus drop is measured from the bottom edge of the shadeplus profile to the bottom edge of the valance profile. Because of tolerances in fabric thicknesses the drop may be shorter by up to 5 cm.

A shadeplus with gear is available in drops of 150 cm and 190 cm.

A shadeplus is not possible with PVC covers.

A shadeplus with motor is not possible.

Coupled folding-arm awnings are not available.

frame colours		
	RAL 9016 traffic white	●
	RAL 8019 grey brown	●
	RAL 9006 metallic aluminium	●
	RAL 1015 light ivory	●
	5206 non-standard RAL colour	○

markilux 1300 stretch

fixings and accessories

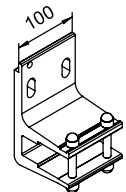
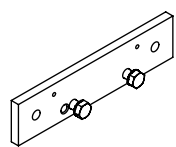
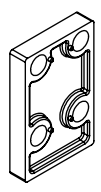
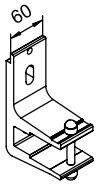
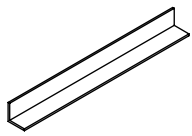
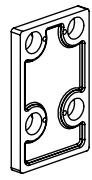
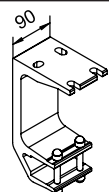
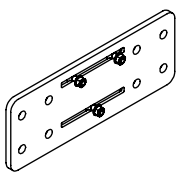
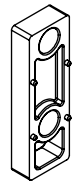
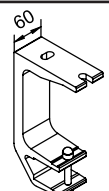
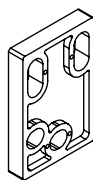
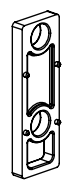
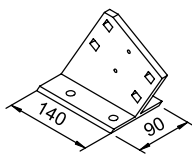
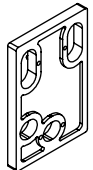
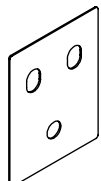
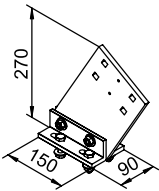
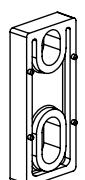
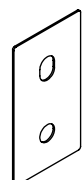
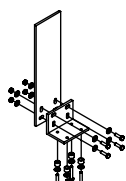
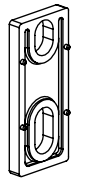
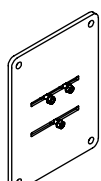
 <p>100</p> <p>Face fixture bracket assembly</p> <p>100mm</p> <p>71664.</p>	 <p>Additional eaves fixture plate</p> <p>60x260x12mm</p> <p>75383.</p>	 <p>Spacer plate for top fixture</p> <p>90x140x20mm N.B! stack to a max. of 200 mm</p> <p>716311</p>
 <p>60</p> <p>Face fixture bracket assembly</p> <p>60mm</p> <p>71665.</p>	 <p>Angled profile for eaves fixtures</p> <p>100x100mm available by the metre, undrilled</p> <p>79380.</p>	 <p>Spacer plate for top fixture</p> <p>90x140x12mm</p> <p>716411</p>
 <p>90</p> <p>Top fixture bracket assembly</p> <p>90mm</p> <p>71666.</p>	 <p>Component assembly spreader plate A</p> <p>160x430x12mm</p> <p>75326.</p>	 <p>Spacer plate for top fixture</p> <p>45x140x20mm N.B! stack to a max. of 200 mm</p> <p>716261</p>
 <p>60</p> <p>Top fixture bracket assembly</p> <p>60mm</p> <p>71667.</p>	 <p>Spacer plate for face fixture</p> <p>100x150x20mm N.B! stack to a max. of 200 mm</p> <p>718231</p>	 <p>Spacer plate for top fixture</p> <p>45x140x12mm</p> <p>716371</p>
 <p>140</p> <p>90</p> <p>Eaves fixture bracket</p> <p>140mm</p> <p>71612.</p>	 <p>Spacer plate for face fixture</p> <p>100x150x12mm</p> <p>718241</p>	 <p>Cover plate for external insulation</p> <p>140x180x2mm</p> <p>71835.</p>
 <p>270</p> <p>150</p> <p>90</p> <p>Eaves fixture bracket assembly</p> <p>270mm</p> <p>71659.</p>	 <p>Spacer plate for face fixture</p> <p>60x140x12mm N.B! stack to a max. of 200 mm</p> <p>716321</p>	 <p>Cover plate for external insulation</p> <p>100x180x2mm</p> <p>71836.</p>
 <p>Angle and fixture plate for eaves fixture</p> <p>machine finish</p> <p>716620</p>	 <p>Spacer plate for face fixture</p> <p>60x140x20mm</p> <p>71642.</p>	 <p>Component assembly spreader plate B</p> <p>300x400x12mm</p> <p>75325.</p>

. = Please insert the RAL No. (please refer to the section on "Coatings")

fixings and accessories

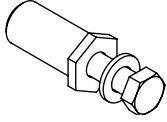
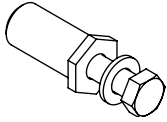
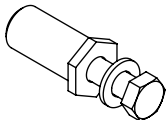
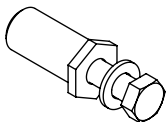
 753891	Reduction assembly M 16 - M 12 / SW 27 50mm length (please refer to "Technical Information")
 754901	Reduction assembly M 10 - M 10 / SW 27 50mm length (please refer to "Technical Information")
 754911	Reduction assembly M 12 - M 10 / SW 27 50mm length (please refer to "Technical Information")
 754921	Reduction assembly M 16 - M 10 / SW 27 50mm length (please refer to "Technical Information")

. = Please insert the RAL No.
(please refer to the section on "Coatings")

Face fixture with spreader plate A

Pull-out force [N=Newton] per fixture point according to EN 13561, wind resistance class 2

		compression-proof substrate						non compression-proof substrate							
		M [cm]						M [cm]							
		150	175	200	225	250	300	350	150	175	200	225	250	300	350
H [cm]		FB [N]						FB [N]							
150		150	166	---	---	---	---	---	212	235	---	---	---	---	---
200		237	263	289	---	---	---	---	336	373	410	---	---	---	---
250		---	393	431	469	507	---	---	---	558	612	666	721	---	---
300		---	---	587	639	692	797	---	---	---	834	908	983	1132	---
350		---	---	---	847	916	1055	1193	---	---	---	1204	1302	1499	1695
HT BHT		2 100 mm						2 100 mm							
BP		2						2							
BM		16						16							

The pull-out force refers to the vertical centre to centre measurement between the fixture points of 76 mm. In the case of spreader plates a washer conforming to DIN 9021 must be used.

- M = overall awning width
- H = extension
- FB = pull-out force per fixing point
- HT | BHT = bracket quantity | width
- BP = no. of spreader plates
- BM = no. of fixing points
- SD = coverboard

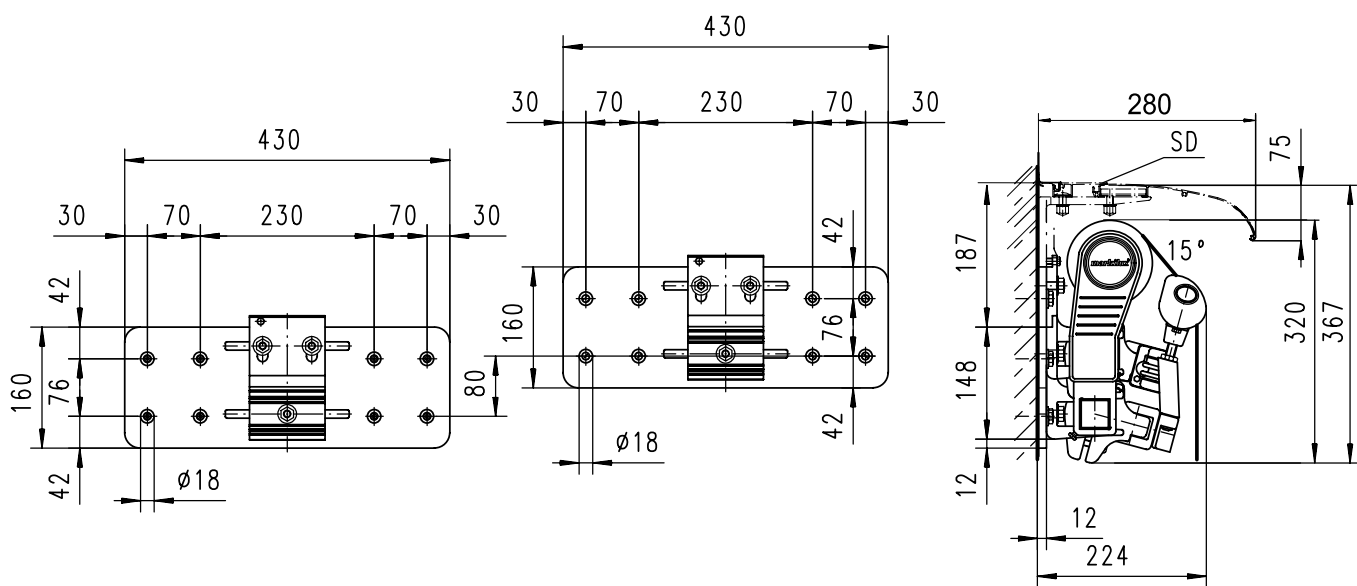

dimensions in mm

Face fixture with spreader plate B

Pull-out force [N=Newton] per fixture point according to EN 13561, wind resistance class 2

H [cm]	compression-proof substrate							non compression-proof substrate						
	M [cm]							M [cm]						
	150	175	200	225	250	300	350	150	175	200	225	250	300	350
FB [N]	88	98	---	---	---	---	---	92	102	---	---	---	---	---
150	140	155	171	---	---	---	---	146	162	178	---	---	---	---
200	---	232	255	277	300	---	---	---	242	266	289	313	---	---
250	---	---	347	378	409	471	---	---	---	362	394	427	492	---
300	---	---	---	501	542	624	706	---	---	---	523	565	651	736
350	2 100 mm							2 100 mm						
HT BHT	2							2						
BP	8							8						
BM	8							8						

The pull-out force refers to the vertical centre to centre measurement between the fixture points of 350 mm. In the case of spreader plates a washer conforming to DIN 9021 must be used.

- M = overall awning width
- H = extension
- FB = pull-out force per fixing point
- HT | BHT = bracket quantity | width
- BP = no. of spreader plates
- BM = no. of fixing points

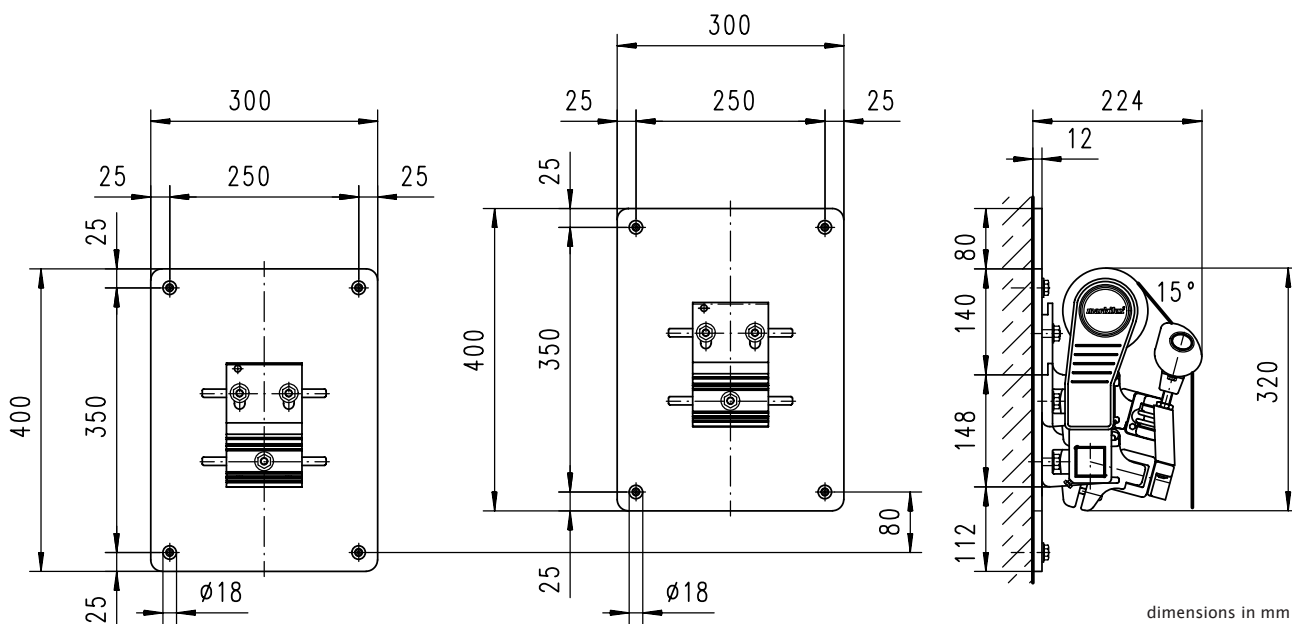

Face fixture with shadeplus

Pull-out force [N=Newton] per fixture point according to EN 13561, wind resistance class 2

		compression-proof substrate						non compression-proof substrate							
		M [cm]						M [cm]							
		150	175	200	225	250	300	350	150	175	200	225	250	300	350
H [cm]		FB [N]						FB [N]							
150		349	389	---	---	---	---	---	403	450	---	---	---	---	---
200		543	606	669	---	---	---	---	627	700	773	---	---	---	---
250		---	891	981	1072	1162	---	---	---	1030	1134	1239	1343	---	---
300		---	---	1323	1445	1568	1813	---	---	---	1529	1670	1812	2095	---
350		---	---	---	1897	2056	2375	2693	---	---	---	2192	2376	2744	3112
HT BHT		2 100 mm						2 100 mm							
BM		6						6							

The pull-out force refers to the vertical centre to centre measurement between the fixture points of 90 mm. If this measurement is reduced, the pull-out force increases by 14% in the case of **compression-proof** substrates and by 19% in the case of **non-compression-proof** substrates.

- M = overall awning width
- H = extension
- FB = pull-out force per fixing point
- HT | BHT = bracket quantity | width
- BM = no. of fixing points
- SD = coverboard

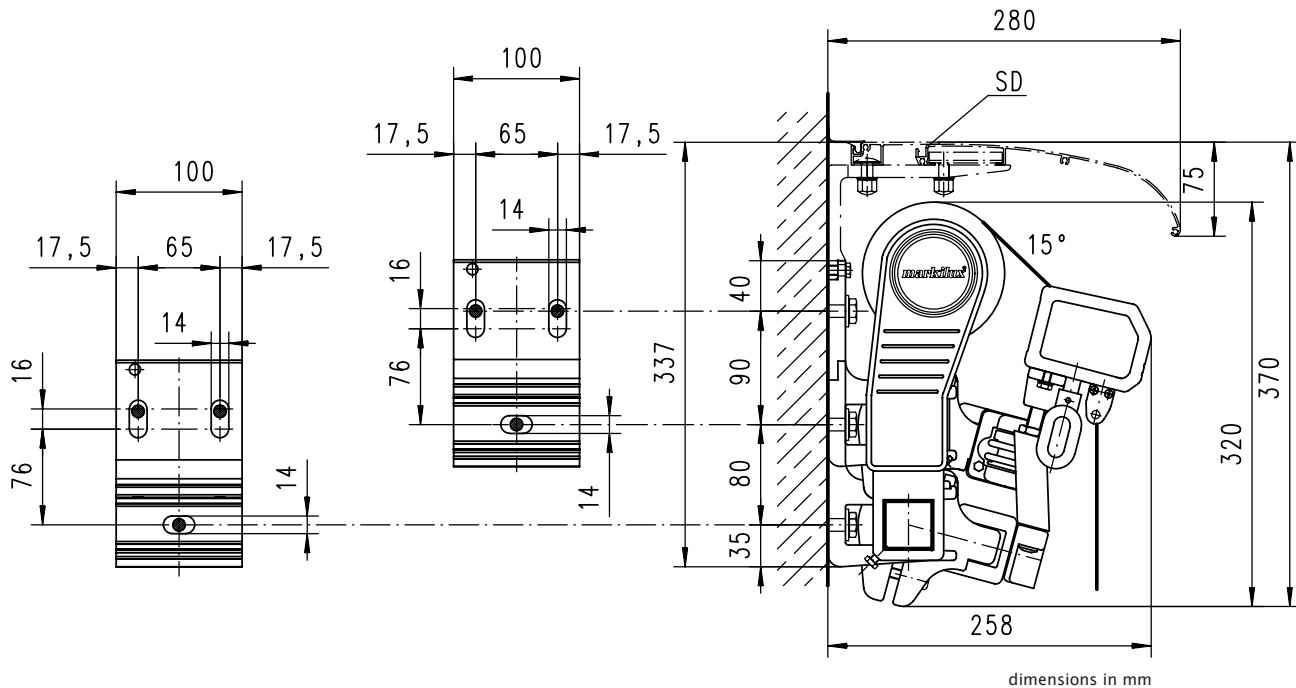

Face fixture with shadeplus and spreader plate A

Pull-out force [N=Newton] per fixture point according to EN 13561, wind resistance class 2

compression-proof substrate								non compression-proof substrate							
H [cm]	M [cm]							M [cm]							
	150	175	200	225	250	300	350	150	175	200	225	250	300	350	
FB [N]								FB [N]							
150	170	190	---	---	---	---	---	242	270	---	---	---	---	---	
200	264	295	325	---	---	---	---	375	419	462	---	---	---	---	
250	---	432	476	520	564	---	---	---	615	677	739	802	---	---	
300	---	---	641	701	760	879	---	---	---	911	996	1080	1249	---	
350	---	---	---	919	996	1150	1304	---	---	---	1306	1415	1635	1854	
HT BHT	2 100 mm							2 100 mm							
BP	2							2							
BM	16							16							

The pull-out force refers to the vertical centre to centre measurement between the fixture points of 76 mm. In the case of spreader plates a washer conforming to DIN 9021 must be used.

- M = overall awning width
- H = extension
- FB = pull-out force per fixing point
- HT | BHT = bracket quantity | width
- BP = no. of spreader plates
- BM = no. of fixing points
- SD = coverboard

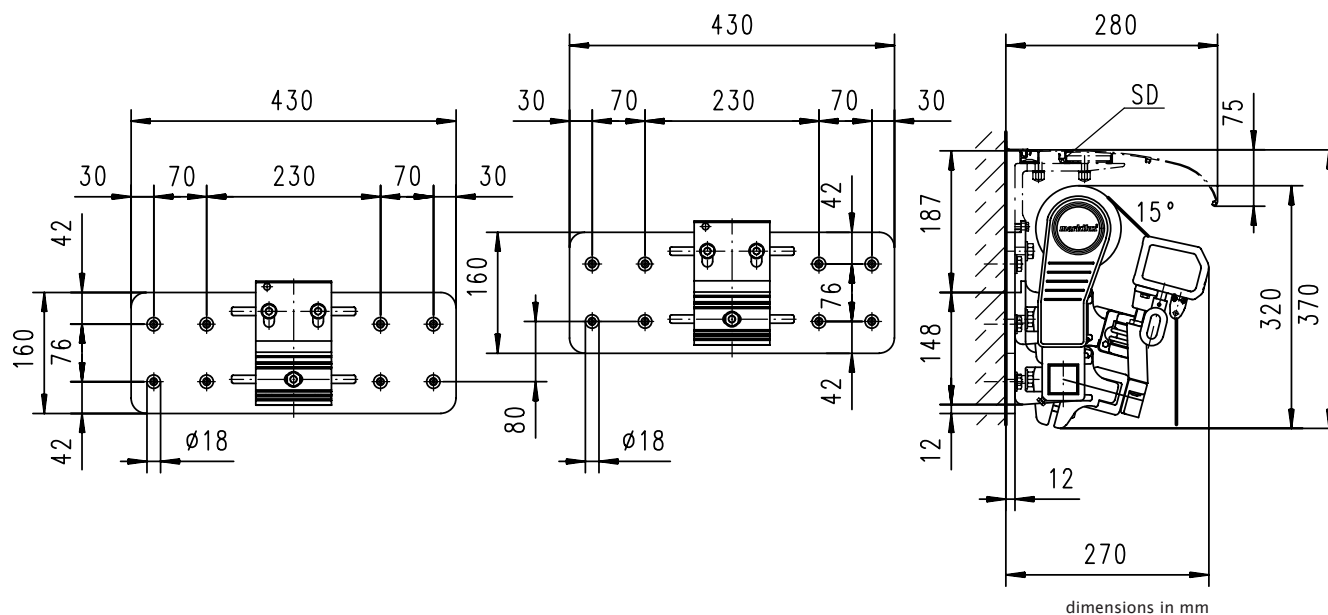

Face fixture with shadeplus and spreader plate B

Pull-out force [N=Newton] per fixture point according to EN 13561, wind resistance class 2

H [cm]	compression-proof substrate							non compression-proof substrate						
	M [cm]							M [cm]						
	150	175	200	225	250	300	350	150	175	200	225	250	300	350
FB [N]	101	112	---	---	---	---	---	105	117	---	---	---	---	---
150	156	174	192	---	---	---	---	163	182	201	---	---	---	---
200	---	256	282	308	334	---	---	---	267	294	321	348	---	---
250	---	---	379	415	450	520	---	---	---	396	432	469	542	---
300	---	---	---	544	589	681	772	---	---	---	567	615	710	805
350	2 100 mm							2 100 mm						
HT BHT	2							2						
BP	8							8						
BM	8							8						

The pull-out force refers to the vertical centre to centre measurement between the fixture points of 350 mm. In the case of spreader plates a washer conforming to DIN 9021 must be used.

- M = overall awning width
- H = extension
- FB = pull-out force per fixing point
- HT | BHT = bracket quantity | width
- BP = no. of spreader plates
- BM = no. of fixing points

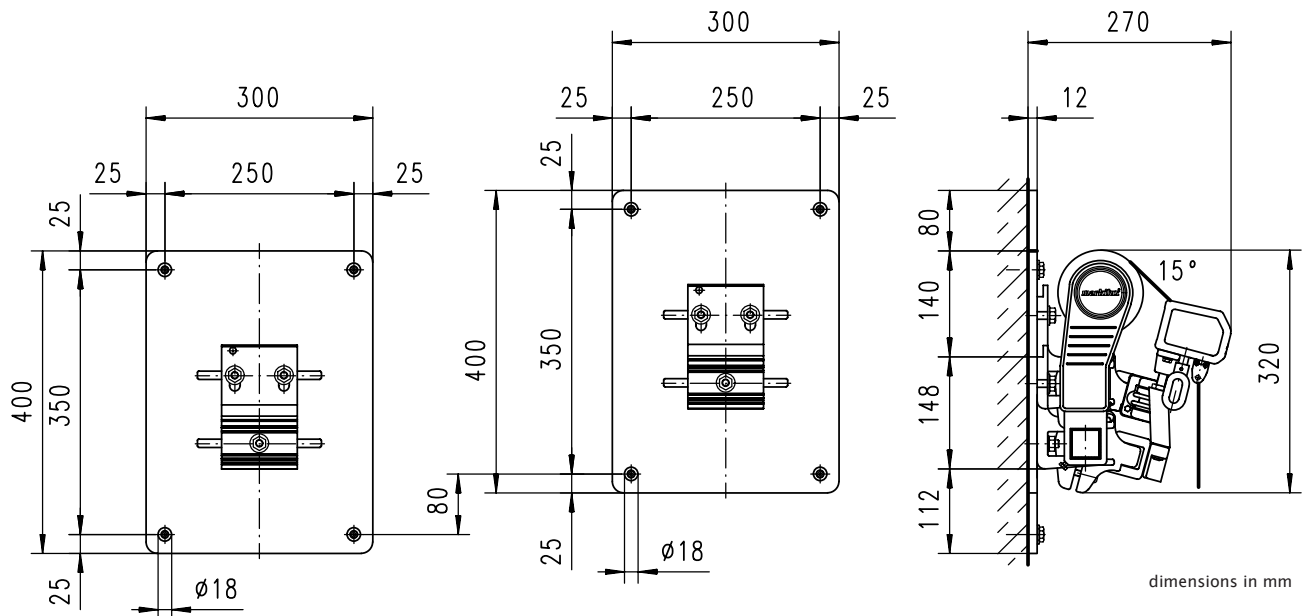

Top fixture

Pull-out force [N=Newton] per fixture point according to EN 13561, wind resistance class 2

H [cm]	compression-proof substrate							non compression-proof substrate						
	M [cm]							M [cm]						
	150	175	200	225	250	300	350	150	175	200	225	250	300	350
FB [N]														
150	320	356	---	---	---	---	---	436	485	---	---	---	---	---
200	485	541	596	---	---	---	---	670	746	822	---	---	---	---
250	---	788	866	945	1024	---	---	---	1095	1203	1312	1420	---	---
300	---	---	1163	1269	1375	1587	---	---	---	1622	1770	1917	2211	---
350	---	---	---	1666	1803	2078	2354	---	---	---	2329	2521	2905	3288
HT BHT	2 90 mm							2 90 mm						
BM	8							8						

The pull-out force refers to the horizontal centre to centre measurement between the fixture points of 80 mm.

M = overall awning width
 H = extension
 FB = pull-out force per fixing point
 HT | BHT = bracket quantity | width
 BM = no. of fixing points

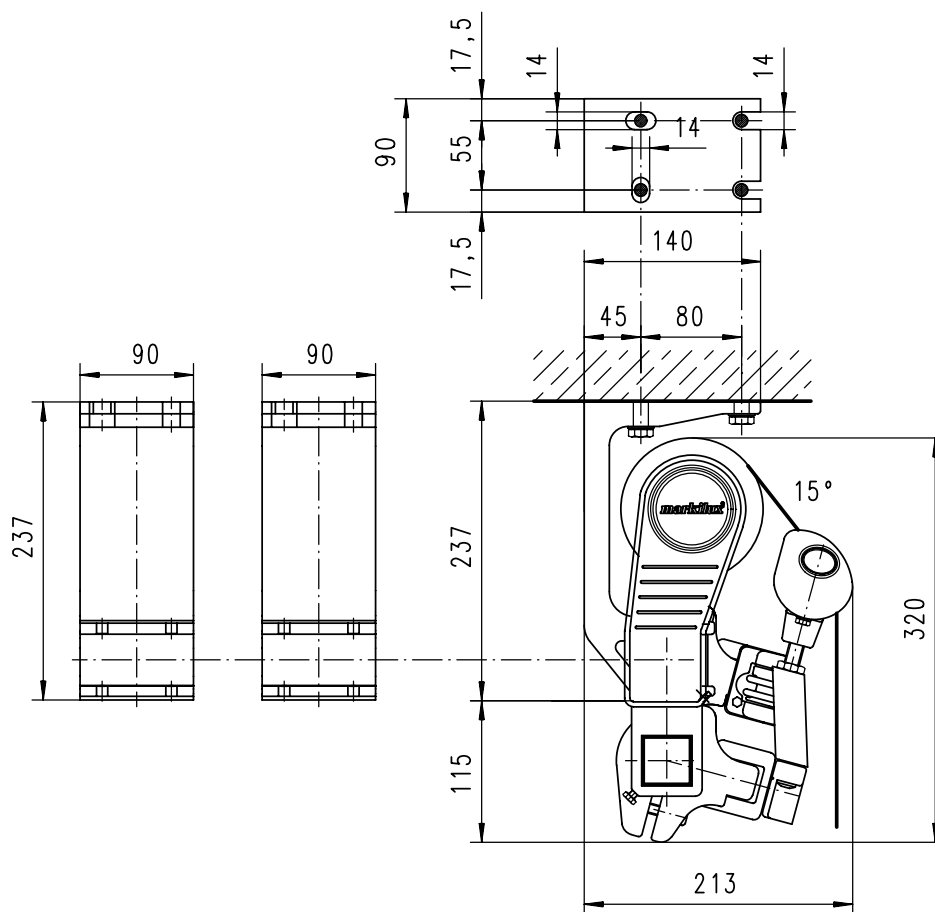

dimensions in mm

Top fixture with shadeplus

Pull-out force [N=Newton] per fixture point according to EN 13561, wind resistance class 2

H [cm]	compression-proof substrate							non compression-proof substrate						
	M [cm]							M [cm]						
	150	175	200	225	250	300	350	150	175	200	225	250	300	350
FB [N]														
150	359	402	---	---	---	---	---	491	550	---	---	---	---	---
200	537	601	666	---	---	---	---	743	831	920	---	---	---	---
250	---	864	953	1043	1132	---	---	---	1202	1326	1450	1574	---	---
300	---	---	1267	1386	1505	1743	---	---	---	1770	1935	2101	2432	---
350	---	---	---	1802	1955	2261	2566	---	---	---	2523	2736	3162	3589
HT BHT	2 90 mm							2 90 mm						
BM	8							8						

The pull-out force refers to the horizontal centre to centre measurement between the fixture points of 80 mm.

M = overall awning width
 H = extension
 FB = pull-out force per fixing point
 HT | BHT = bracket quantity | width
 BM = no. of fixing points

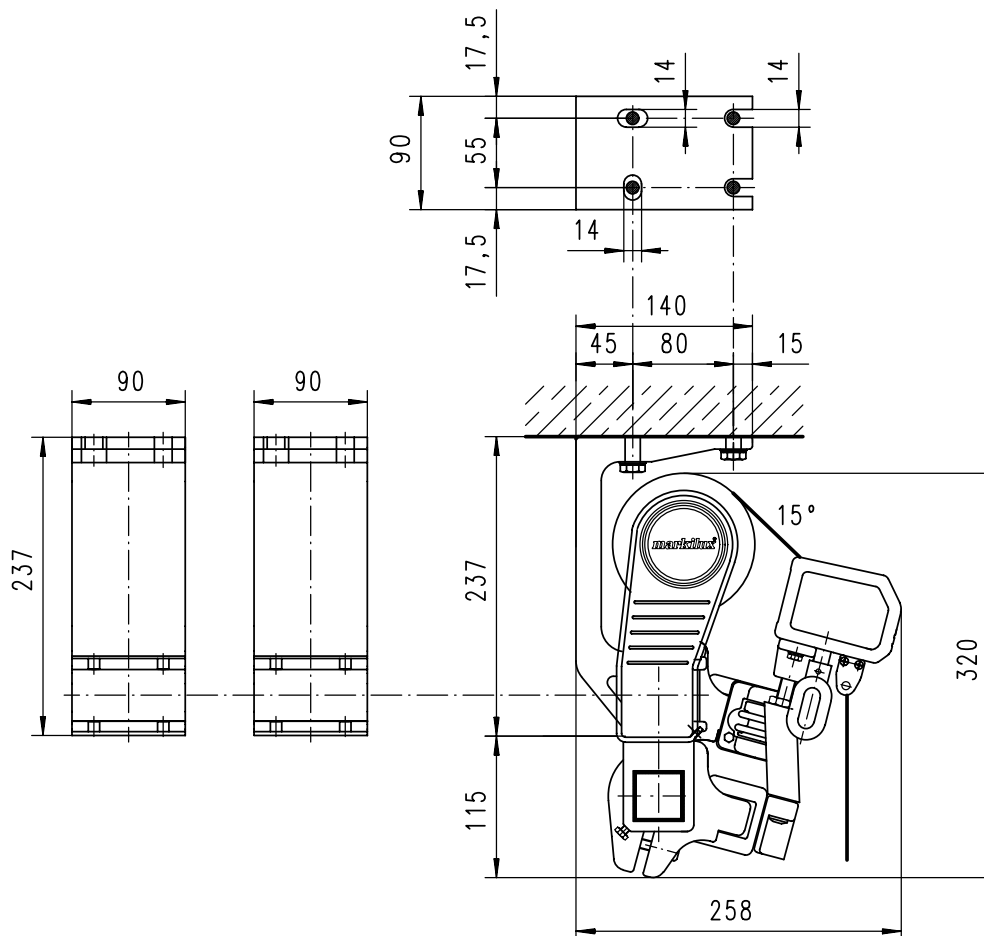

dimensions in mm

Eaves/Roof timber fixture

Pull-out force [N=Newton] for the fixture bracket next to the arm according to EN 13561, wind resistance class 2

H [cm]	Torque							shear force						
	M [cm]							M [cm]						
	150	175	200	225	250	300	350	150	175	200	225	250	300	350
	Md [Nm]							FS [N]						
150	64	71	---	---	---	---	---	783	872	---	---	---	---	---
200	101	112	123	---	---	---	---	1199	1335	1472	---	---	---	---
250	---	168	185	201	217	---	---	---	1956	2150	2345	2539	---	---
300	---	---	252	274	297	342	---	---	---	2895	3158	3421	3947	---
350	---	---	---	364	393	453	512	---	---	---	4154	4496	5181	5865
HT	2							2						
BM	8							8						

The shear force are calculated from 2 fixture points per bracket, because depending on the roof pitch it cannot be guaranteed that 4 fixture points per bracket can be used.

- M = overall awning width
- H = extension
- Md = torque value for the bracket next to the arm
- FS = shear force
- HT = bracket
- BM = no. of fixing points

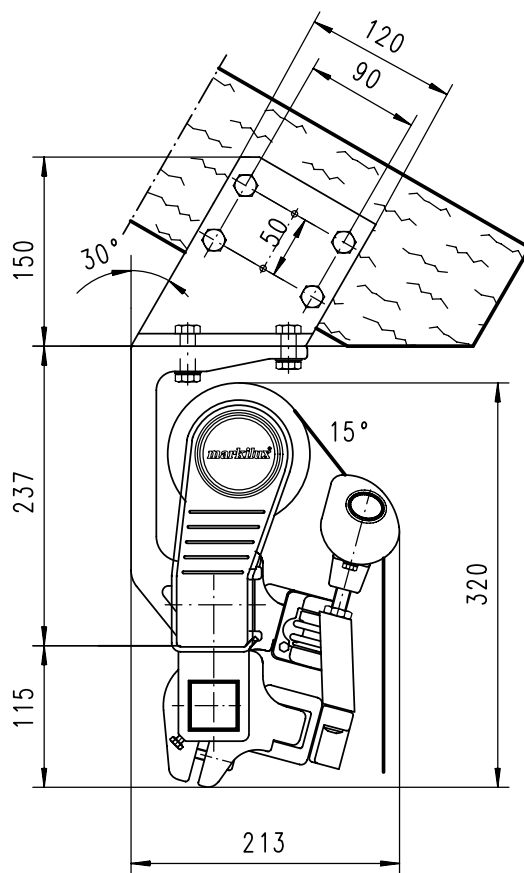

dimensions in mm

Eaves fixture with additional plate

Pull-out force [N=Newton] for the fixture bracket next to the arm according to EN 13561, wind resistance class 2

H [cm]	Torque							shear force						
	M [cm]							M [cm]						
	150	175	200	225	250	300	350	150	175	200	225	250	300	350
	Md [Nm]							FS [N]						
150	64	71	---	---	---	---	---	394	441	---	---	---	---	---
200	101	112	123	---	---	---	---	581	649	717	---	---	---	---
250	---	168	185	201	217	---	---	---	928	1023	1117	1211	---	---
300	---	---	252	274	297	342	---	---	---	1358	1483	1608	1859	---
350	---	---	---	364	393	453	512	---	---	---	1931	2092	2414	2736
HT	2							2						
BM	4							4						

By using the additional flat plate, the shear force is reduced in comparison with conventional eaves fixture.

M = overall awning width
 H = extension
 Md = torque value for the bracket next to the arm
 FS = shear force
 HT = bracket
 BM = no. of fixing points

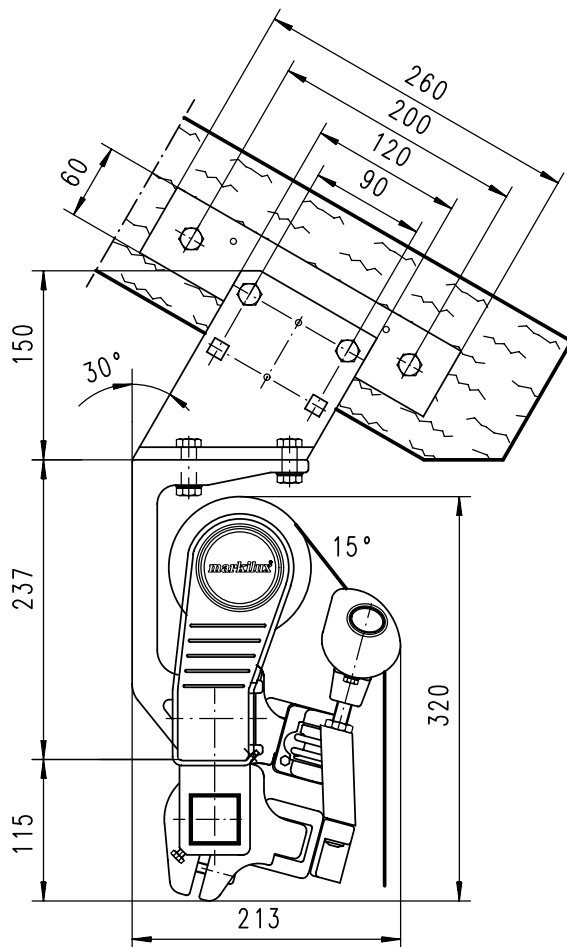

dimensions in mm

markilux 1300 stretch

Bracket range for awnings with 2 folding arms

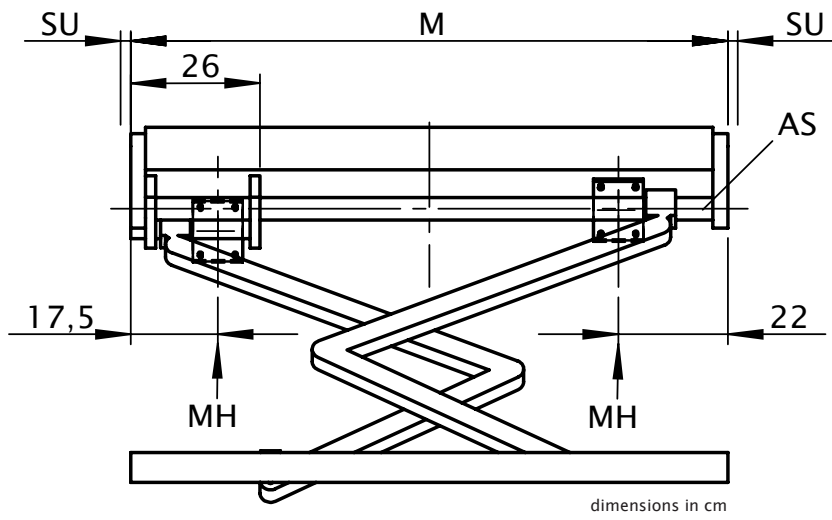

M = overall awning width
MH = bracket centre
AS = Operation side (opposite the lower folding arm)
SU = coverboard overhang 2 cm